

SP688成端手順

※詳細は、当社ホームページをご覧ください。

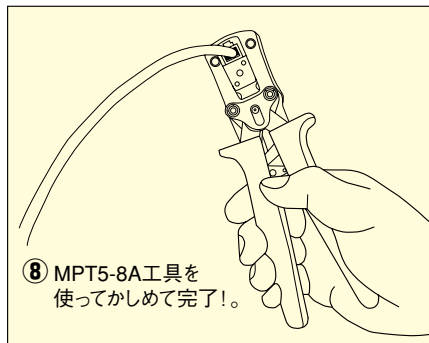
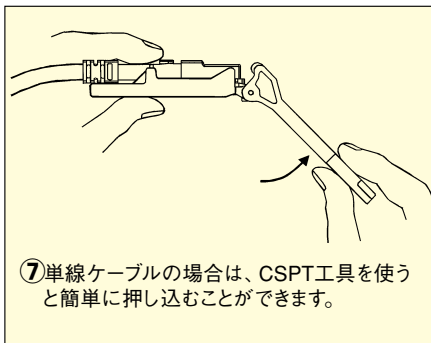
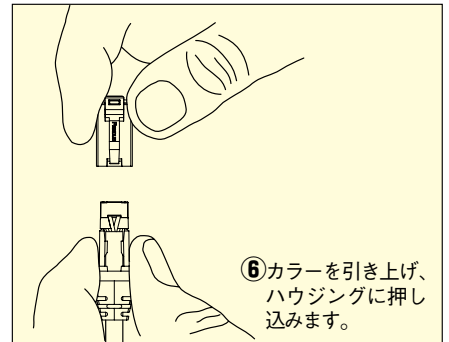
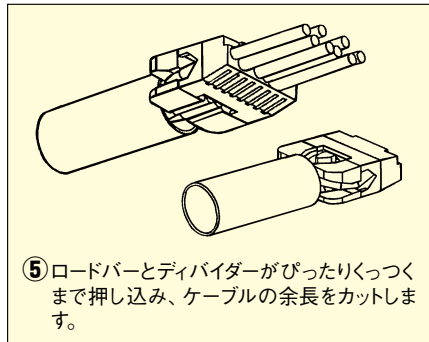
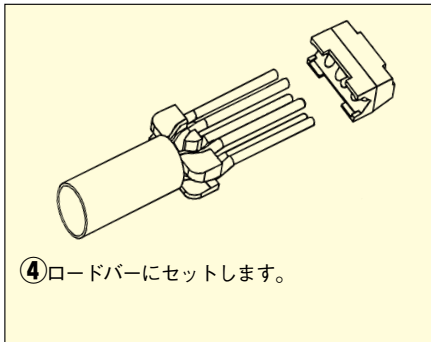
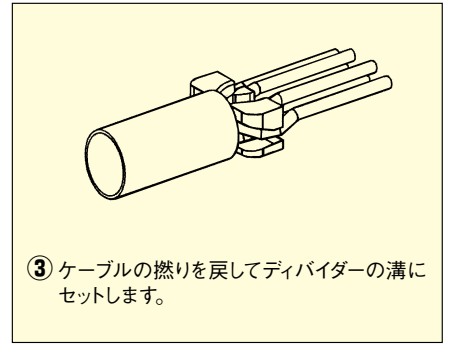
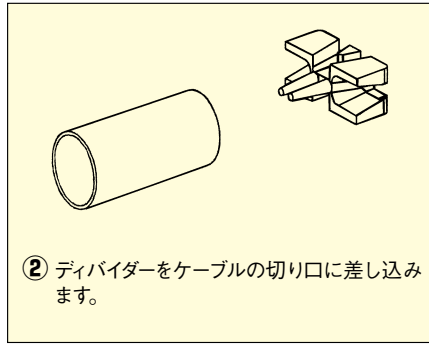
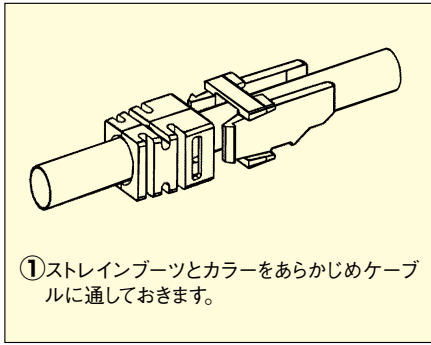

SP688用補充部品

SP688の小部品は補充用にご用意できます。(100個単位)

- ブーツ : MTPSRBCL-C
- カラー : MTX6UTPSRC-C
- ディバイダー : MTPCD-C
- ロードバー : MTX6PLB-C
- ハウジング : RTPSA-C

MP588成端手順 (WPT-8を使用した場合)

※詳細は、当社ホームページをご覧ください。

